

EXHIBITION RESEARCH DOCUMENT (also go to: <http://annewilsonartist.com>)

Anne Wilson and studio interns research utilizing libraries, the Internet, studio practices, interviews, and conversations. Kimberly Pence is the research lead. This is an in-process compilation of information, never intended to be comprehensive.

The title 'Rewinds' calls to mind a returning in time and a freezing of memory (-SB). A rewind also refers to a bobbin that has been wound with left over thread, reused from another source.

Index (click pdf 'pages')

page

- 1 Definitions, thread to glass
- 3 Notes on passive resistance, action research, micro-political, slowness:
Wilson's talking points for interactive discussion
- 5 Bobbin and thread winding drawings by Michael Hunter
- 12 Economic Theories of Labor by Kimberly Pence
- 13 Labor Histories: Reading summaries & research notes by Kimberly Pence
- 20 World Textile Manufacturing: Selected web sites by Kimberly Pence
- 21 Estimated Textile Worker Pay Scales in Various Countries by Kimberly Pence
- 23 Art / Craft / Collective Practices

thread, noun

- 1 a long, thin strand of cotton, nylon, or other fibers used in sewing or weaving.
 - cotton, nylon, or other fibers spun into long, thin strands and used for sewing.
 - (threads) slang for "clothes"
- 2 a thing resembling a thread in length or thinness, in particular
 - chiefly poetic/literary a long, thin line or piece of something : *the river was a thread of silver below them.*
 - [in sing.] something abstract or intangible, regarded as weak or fragile: *keeping the tenuous thread of life attached to a dying body.*
 - a theme or characteristic, typically forming one of several, running throughout a situation or piece of writing : *a common thread running through the scandals was the failure to conduct audits.*
- 3 In computing: a group of linked messages posted on the Internet that share a common subject or theme.
 - a programming structure or process formed by linking a number of separate elements or subroutines, esp. each of the tasks executed concurrently in multithreading.
- 4 (also screw thread) a helical ridge on the outside of a screw, bolt, etc., or on the inside of a cylindrical hole to allow two parts to be screwed together.

bobbin, noun

a cylinder or cone holding thread, yarn, or wire, used esp. in weaving, machine sewing, and lacemaking.

glass, noun

- 1 a hard, brittle substance, typically transparent or translucent, made by fusing sand with soda, lime, and sometimes other ingredients and cooling.

"Transparent and invisible, glass can curve and color space and refract, filter, and shape light. Through the centuries, this material, made from mixed sands treated to achieve a state of rigid liquidity, has been the magical obsession of alchemists, chemists, and engineers and has developed extraordinary mutant qualities."

-- Paola Antonelli, Associate Curator, Department of Architecture and Design, The Museum of Modern Art, New York

"Glass is an amorphous solid meaning that, on the microscopic level, in the process of forming the glass, molecules are heated up and then cooled. As the molecules cool they are left in a disordered (non-crystalline) arrangement; however, sufficient cohesion remains to maintain some amount of rigidity giving us what appears on the macroscopic level to be a solid. Not all physicists agree with this definition; however, it is commonly agreed to as the best definition we have at this point in time."

-- Glass Definition Summary, Is glass liquid or solid? Original by Philip Gibbs, October 1996. [\[Physics FAQ\]](#) - [\[Copyright\]](#)

In glass blowing the term "wrap" or "lip wrap" describes the process of applying a thin line of glass to the object being made. The wrap is usually in a contrasting color and applied for decorative purposes. Glass objects with wraps are usually goblets, glasses, or bowl forms. -KP

Wilson's words from http://annewilsonartist.com/projects/rewinds/text_rewinds.html
"In watching the movement of the gaffers, I realized the relatedness of textile processes to glass -- glass is flexible and can be fibrous when molten. By translating fiber bobbin winding, or rewinding, into glass we are able to produce and exploit aesthetic analogies between these two modes of production."

Anne Wilson making glass rewinds at Pilchuk, with gaffers Nancy Callan and Katherine Gray.

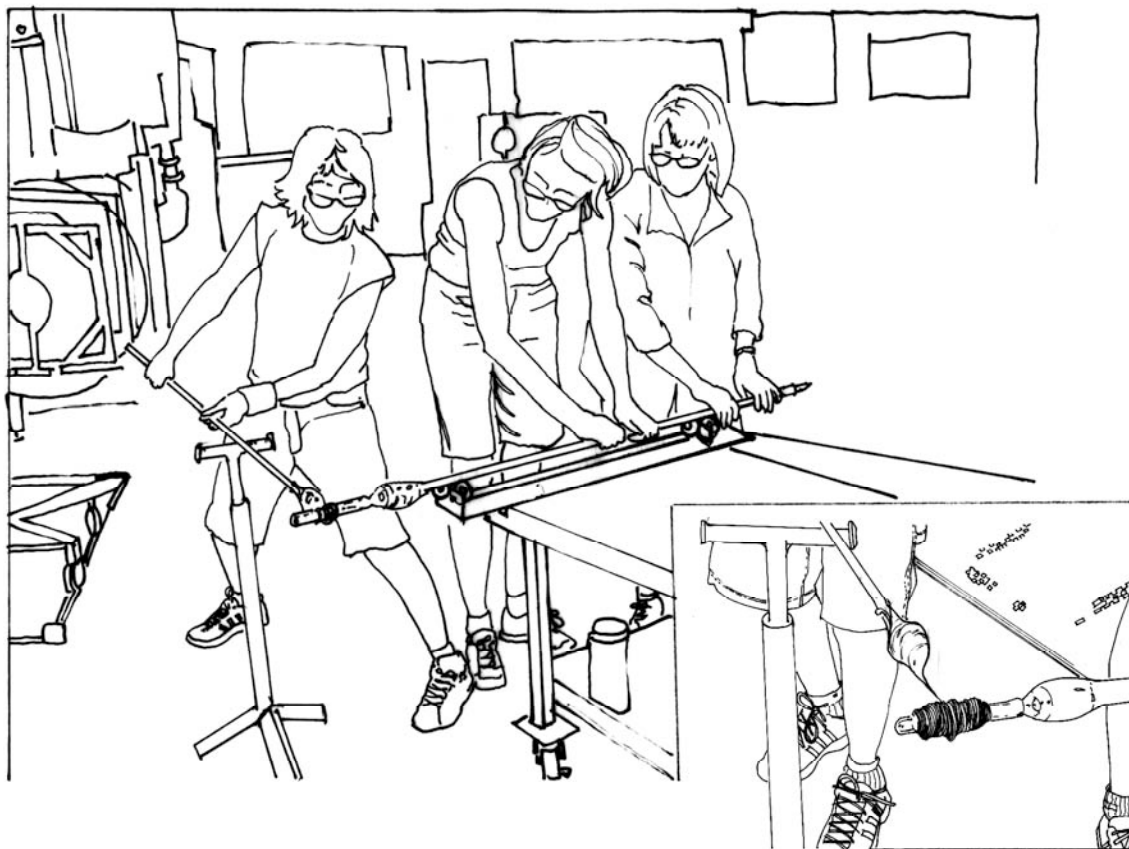

WILSON'S NOTES ON PASSIVE RESISTANCE, ACTION RESEARCH, MICRO-POLITICAL, SLOWNESS -- TALKING POINTS FOR DISCUSSION

PASSIVE RESISTANCE

At 15, I was challenged and radicalized in many ways after leaving my childhood home in Detroit to attend a Quaker boarding school, George School, in Pennsylvania. I was deeply moved by my training in passive resistance techniques and their philosophical basis and examples, such as Gandhi's teachings on non-violent politics. I remember role-playing exercises in religion class where we practiced making our bodies become dead weights to face the aggressive actions of others. In addition, especially moving to me was Gandhi's exhortation to all Indians to practice spinning -- for social, political, economic and spiritual reasons. That struck me as profoundly important, as did Betty Friedan's book *The Feminine Mystique*. These early teachings have deeply affected my position as an artist and educator.

ACTION RESEARCH

Part of my interest in group processes comes from a psychological perspective, and conversations with my psychologist husband, Dr. Michael Nagelbach, who participated in the professional study of group relations. Some of his research was in the history of group relations in the tradition of the A. K. Rice and Tavistock Institutes.

Excerpts and information from:

http://www.tavinstitute.org/work/development/group_relations.php

The Tavistock Institute was founded in 1946 in Britain. Many well-known psychologists and psychiatrists have passed through the Tavistock Institute over the years, and it became known as a key locus for psychoanalysis and psychodynamic theories.

Group Relations conferences, as other methodologies developed at the Tavistock Institute, are rooted in action research and hence offer opportunities for people to learn through experience.

Group Relations conferences offer opportunities to learn about group, organizational and social dynamics; the exercise of authority and power; the interplay between tradition, innovation and change; and the relationship of organizations to their social, political and economic environments.

The conferences, which are educational and part of the Tavistock Institute's professional development stream, emphasize increased insight into irrational, or unconscious, processes we get involved in as we take up our roles in various groups. The basis of group relations theory is that 'groups' move in and out of focusing on their task and back and forth between a number of different defensive positions based on unarticulated 'group' anxieties.

MICRO-POLITICAL

I've often thought of a small group (a class, an artist collaborative, an administrative team) as being a microcosm of political tensions and resolutions that are likened to larger political systems. I have worked with faculty and student groups as an educator my entire professional life, and created learning environments of diverse kinds, participating in and witnessing group dynamics. More recently, I have been exploring group processes in my art practice.

In relation to collaborative art practices, I appreciated a passage by Rene Gabri in a book called *Taking the Matter into Common Hands* where he says: "I do believe there is something inherently more political in collaboration. I do think that working with others invites micro-political experiences, because you are inevitably faced with other views, positions, modes of doing, languages, experiences, forms of communication, which you have to not only take into account, but actually deal with as an equal, negotiate through or even give in to." (Billing, Johanna, Lind, Maria, Nilsson, Lars, editors. "Postscript from Rene Gabri," *Taking the Matter into Common Hands, On Contemporary Art and Collaborative Practices*. London: Black Dog Publishing, 2007, p. 127-128.)

SLOWNESS

As part of our current service economy, computers and digital technologies have become the dominant form of communication and information processing. In this culture of the screen, experiences of body-time, material physicality and handwork are less common. I am interested in reinvigorating the sphere of embodied human experience, and slowness, in a complementary relationship to the speed and distancing of new digital technologies.

RESEARCH

This is an exceptional book about teaching, from a radical egalitarian, non-hierarchical position; it's a book I recommend to all teachers. -AW

Rancière, Jacques. *The Ignorant Schoolmaster, Five Lessons in Intellectual Emancipation*. Stanford, CA: Stanford University Press, 1991.

"This extraordinary book can be read on several levels. Primarily, it is the story of Joseph Jacotot, an exiled French schoolteacher who discovered in 1818 an unconventional teaching method that spread panic throughout the learned community of Europe. Knowing no Flemish, Jacotot found himself able to teach in French to Flemish students who knew no French; knowledge, Jacotot concluded, was not necessary to teach, nor explication necessary to learn. The results of this unusual experiment in pedagogy led him to announce that all people were equally intelligent. From this postulate, Jacotot devised a philosophy and a method for what he called "intellectual emancipation"--a method that would allow, for instance, illiterate parents to themselves teach their children how to read. The greater part of the book is devoted to a description and analysis of Jacotot's method, its premises, and (perhaps most important) its implications for understanding both the learning process and the emancipation that results when that most subtle of hierarchies, intelligence, is overturned. The book, as Kristin Ross argues in her introduction, has profound implications for the ongoing debate about education and class in France that has raged since the student riots of 1968, and it affords Rancière an opportunity (albeit indirectly) to attack the influential educational and sociological theories of Pierre Bourdieu (and others) that Rancière sees as perpetuating inequality." -GB

DRAWINGS BY MICHAEL HUNTER

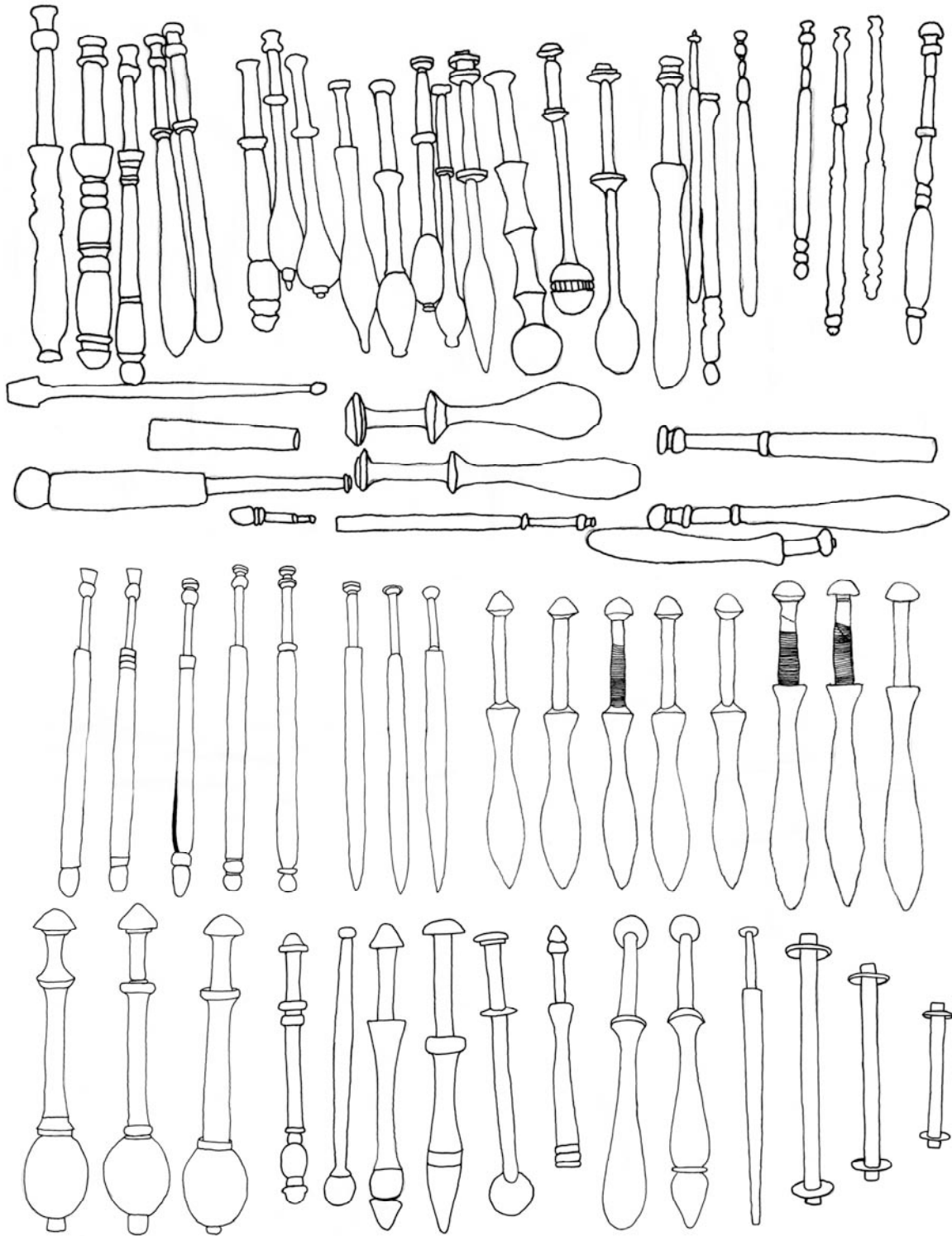

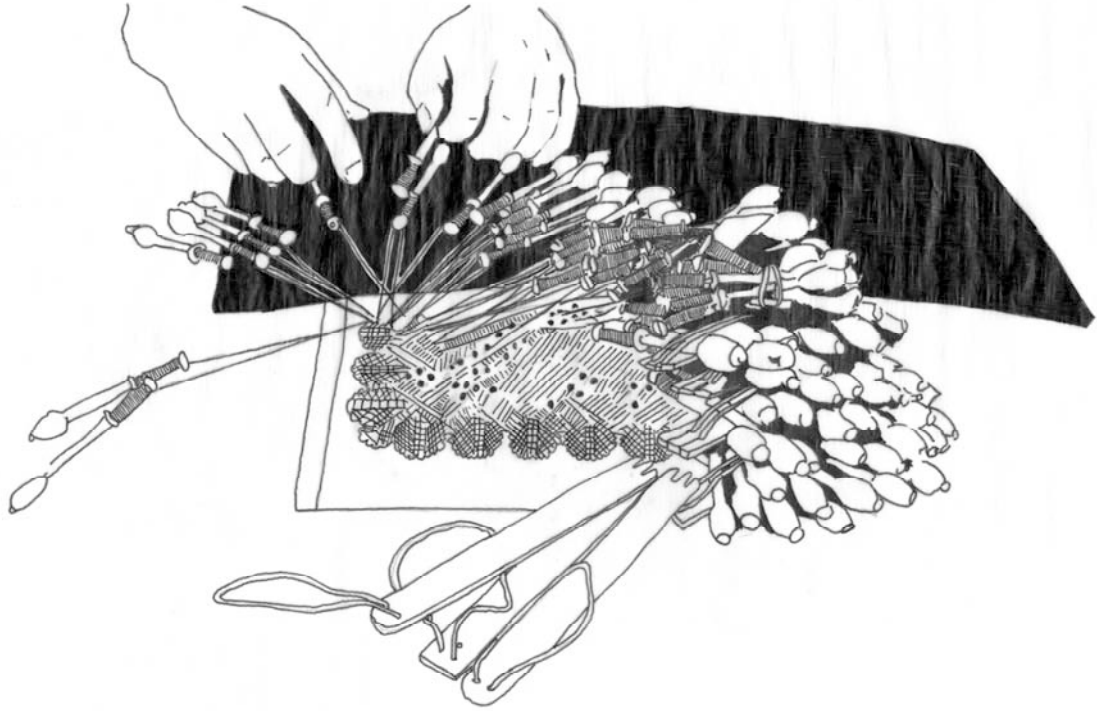

Making bobbin lace

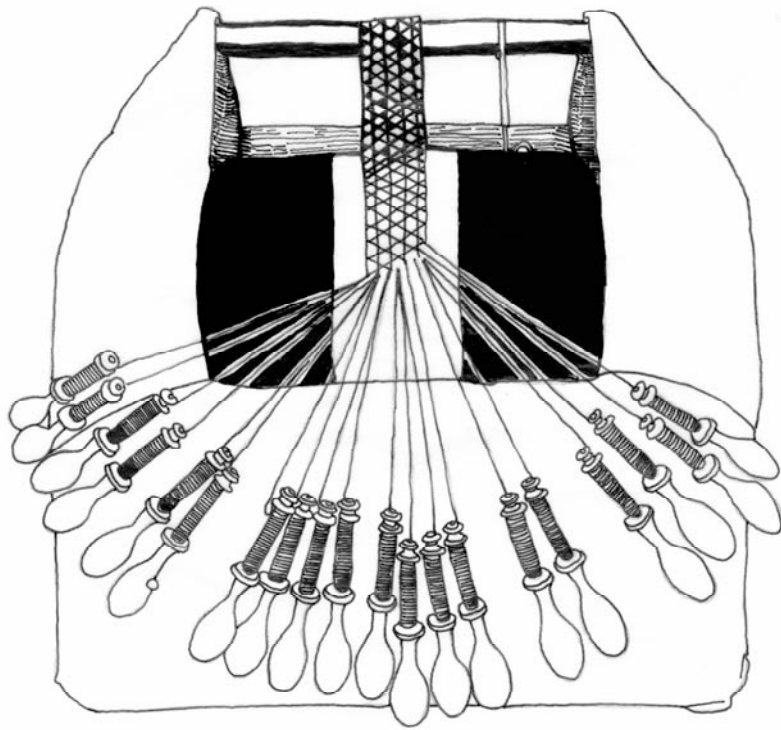

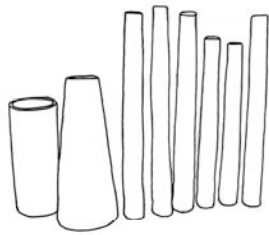
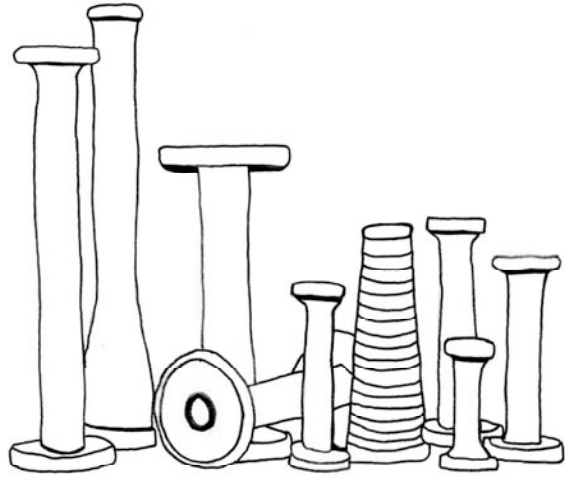
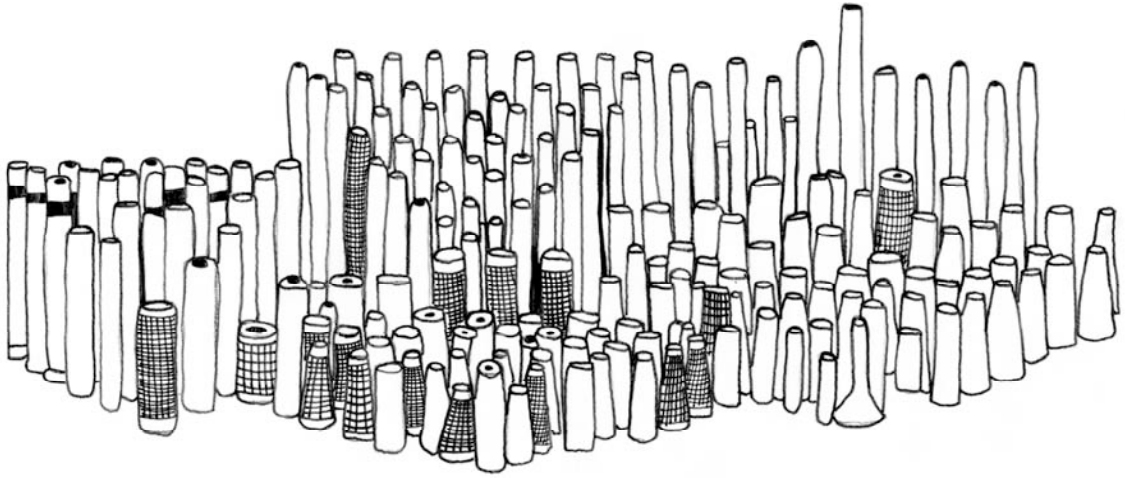

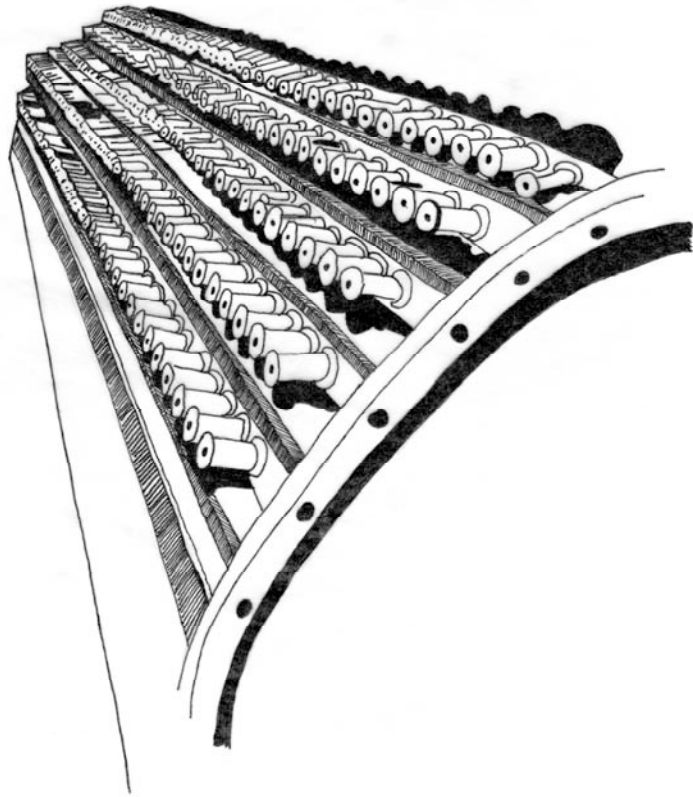

Bobbins on a creel, silk mill, UK

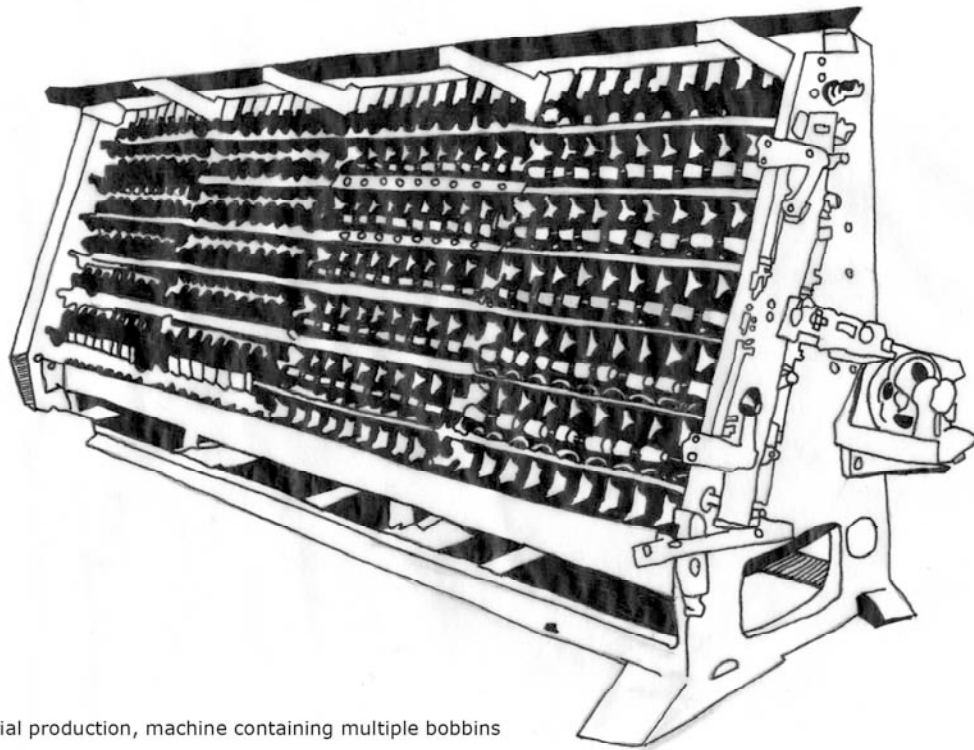

Industrial production, machine containing multiple bobbins

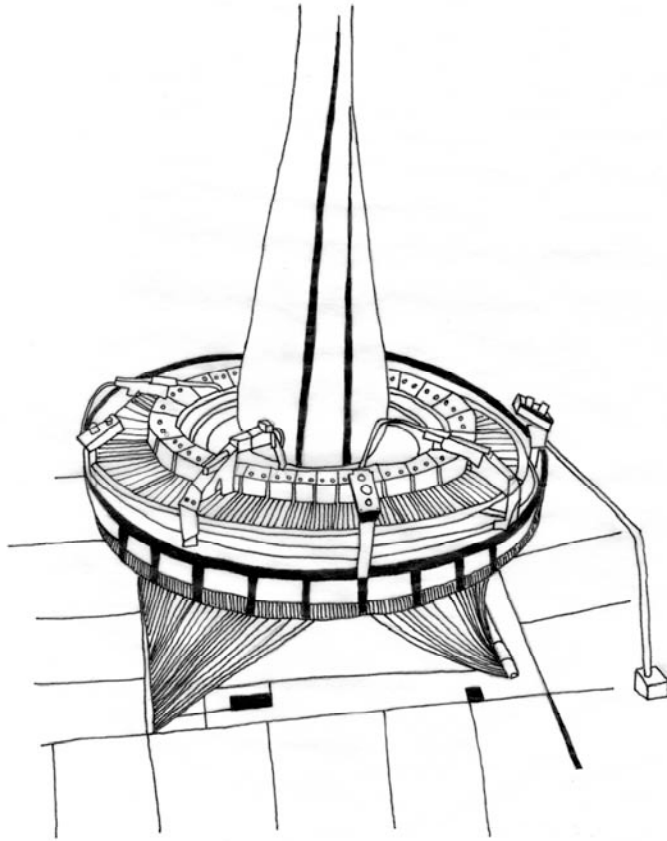

Bag making mill, Turkey (vertical threads to be wound onto bobbins)

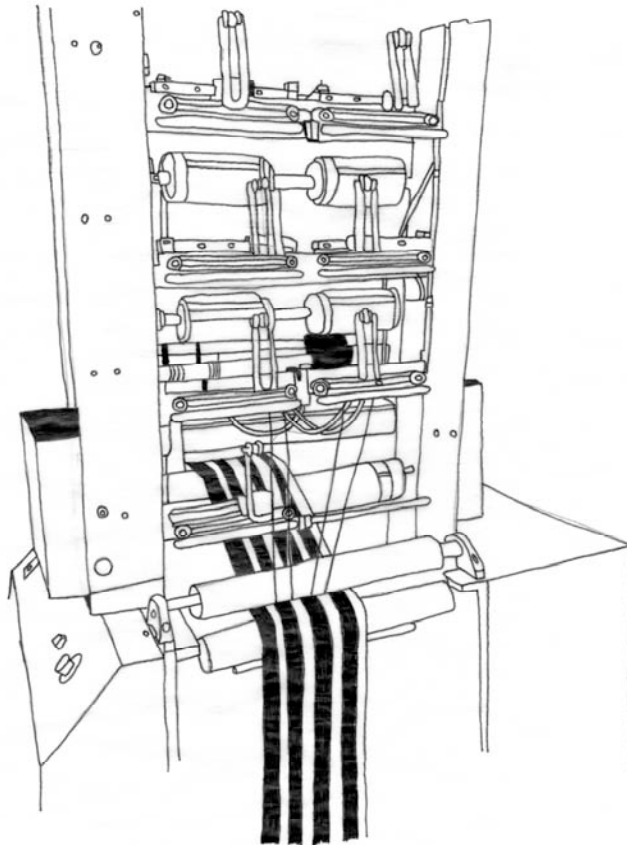

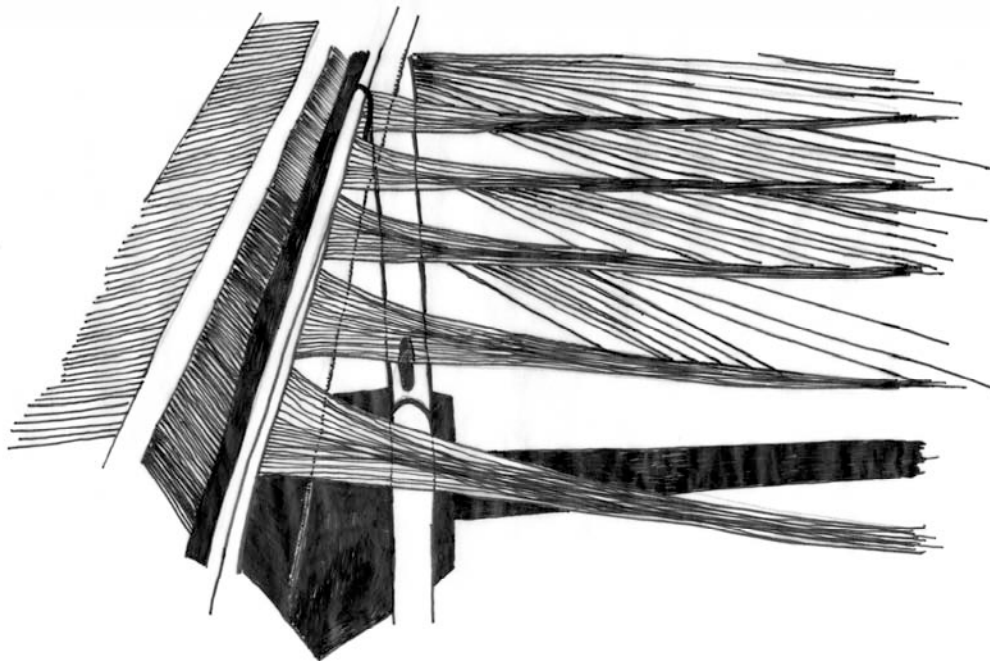
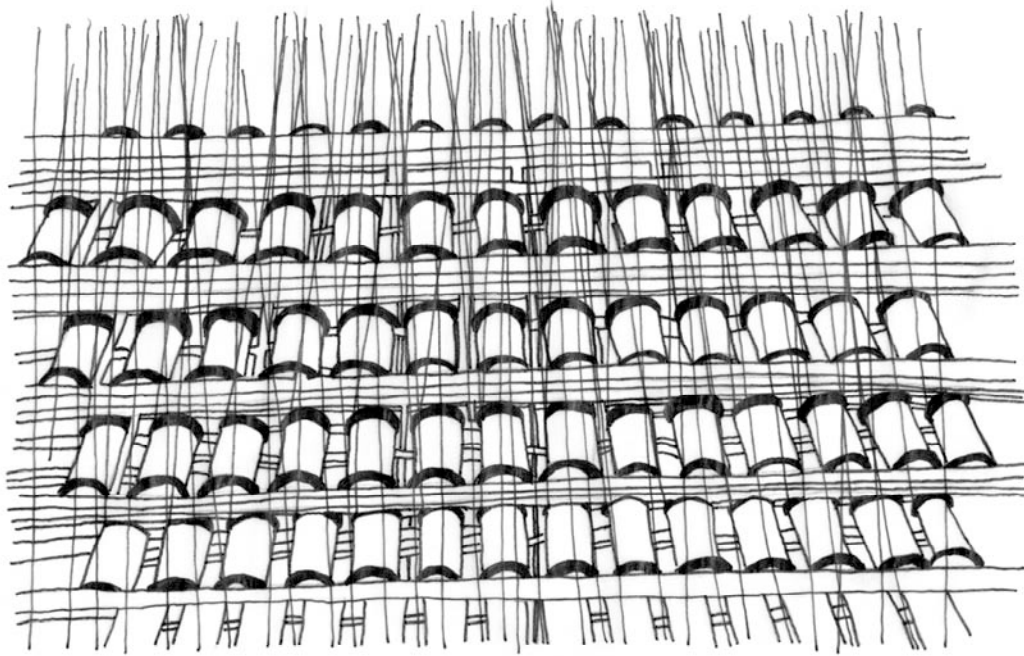

Silk threads from bobbins are sleyed through a reed on a weaving loom

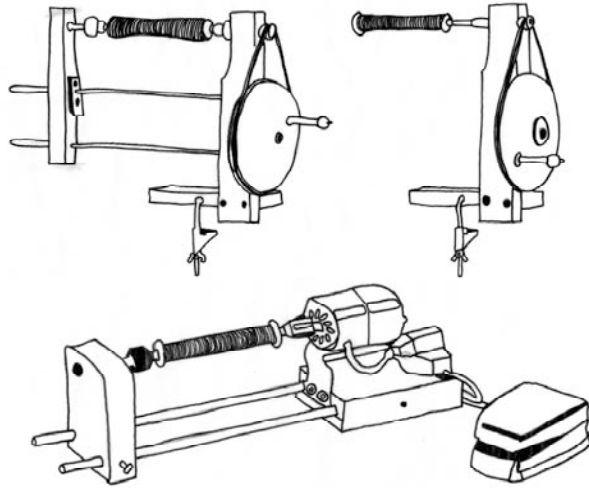

Individual electric and manual hand crank bobbin winders

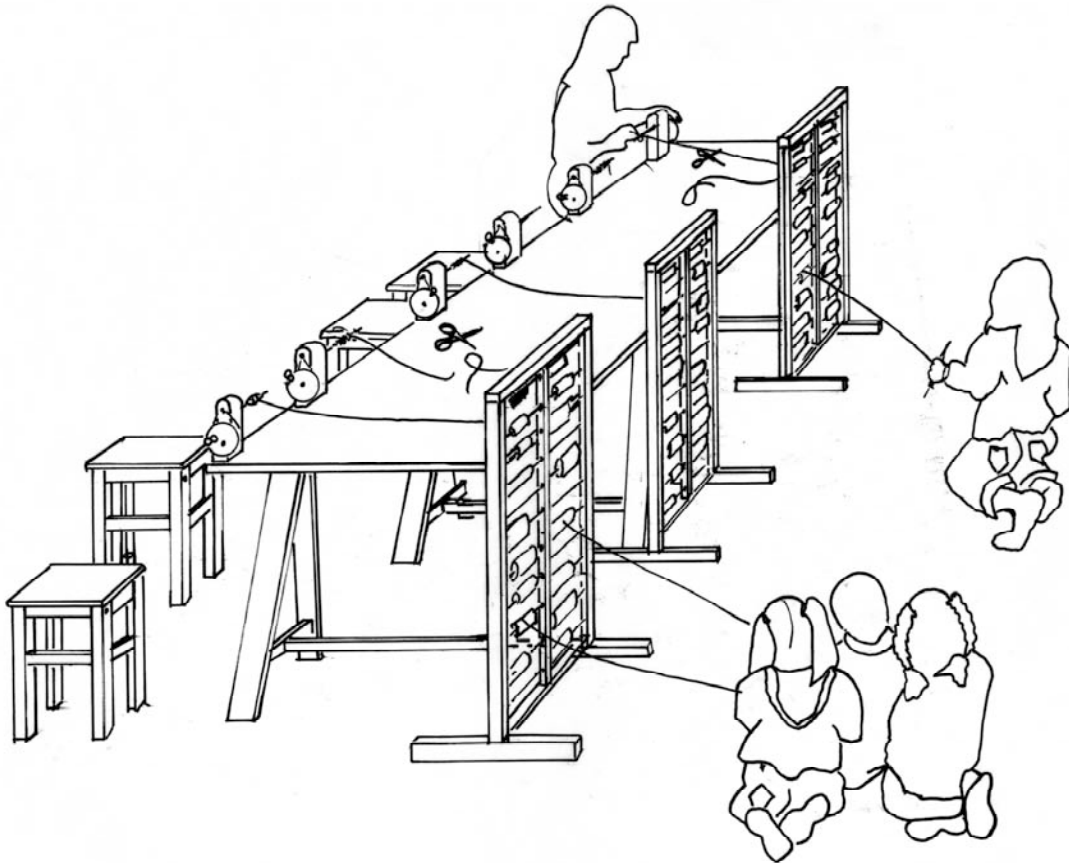

KMA, proposed winding production site (drawing by Kimberly Pence)

DEFINITIONS AND READING SUMMARIES BY KIMBERLY PENCE

ECONOMIC THEORIES OF LABOR

Smithian economics

Adam Smith (1723 – 1790) Wrote *The Wealth of Nations*, installing himself as the leading expositor of economic thought. From The Library of Economics and Liberty: <http://www.econlib.org/library/Enc/bios/Smith.html>

Taylorism (term developed by Fredrick Winslow Taylor)

Developed: 1880–1890; first published under the title *Shop Management* in 1905

"Scientific Management": popular term used in reference to Taylorism

Aim: "analyze and synthesize workflow processes improving labor productivity"

Synopsis of theory: Develop a standard method for performing each job. Select appropriate workers for each job and train them in that job only. Eliminate interruptions to workers. Management is separate from ownership and follows rules to ensure predictable behavior. Labor is given hierarchical levels of authority. Wage incentives are given to workers to increase output.

All quotes from Wikipedia <http://en.wikipedia.org/wiki/Taylorism>

Fordism (after Henry Ford)

Coined in 1916 to describe Henry Ford's economic philosophy. The philosophy dominated corporate ideology in the US until the 1970's and early 1980's.

Philosophy: "widespread prosperity and high corporate profits can be achieved by high wages that allow the workers to purchase the output they produce..."

Four Key Elements: Division of labor between workers from unskilled to skilled to specialties. Parts and components are highly standardized, eliminating custom production. The implementation of the assembly line and conveyer belt, "to facilitate the quick and efficient fulfillment of tasks." "Together, these four attributes can reduce cost of production of a single product, leading to increased sales and the potential development of mass markets."

All quotes from Wikipedia <http://en.wikipedia.org/wiki/Fordism>

Post-Fordism

"Post-Fordism is the name given to the dominant system of economic production, consumption and associated socio-economic phenomena, in most industrialized countries since the late 20th century.

Post-Fordism is characterized by the following attributes:

- * New information technologies.
- * Emphasis on types of consumers in contrast to previous emphasis on social class.
- * The rise of the service and the white-collar worker.
- * The feminization of the work force.
- * The globalization of financial markets."

Post-Fordism is an evolving theory with three distinct schools of thought:

1. Flexible Specialization or neo-Smithian approach: "Instead of producing generic goods, firms now found it more profitable to produce diverse product lines targeted at different groups of consumer, appealing to their sense of taste and fashion. Instead of investing huge amounts of money on the mass production of a single product, firms now needed to build intelligent systems of labor and machines that were flexible and could quickly respond to the whims of the market."
2. Neo-Schumpeterian approach is dominated by Information and Communication Technology. (ICT)

3. Regulation School also called neo-Marxist "was designed to address the paradox of how capitalism has both a tendency towards crisis, change and instability as well as an ability to stabilize institutions, rules and norms."

All quotes are from Wikipedia <http://en.wikipedia.org/wiki/Post-Fordism>

Globalization

Globalization can be summed up as the process of shifting from a locally centered phenomenon to one that is global. Historically, we've used the term to refer to the Diaspora of the first humans from the African continent to the rest of the globe or to the extension of trade throughout Asia, the Mediterranean, North Africa and Europe due to the Silk Road. Today the term is commonly used to discuss economic conditions such as outsourcing, supply-chains, foreign and direct investment, and the spread of technology.

Piecework

Piece-workers are paid by the number of acceptable "pieces" they produce, hence the term piecework. What they earn varies according to their skill, speed and accuracy, as well as how often the piece they are working on changes and a new product is needed.

LABOR HISTORIES

READING SUMMARY

From: Howard, Allan. "Labor History and Sweatshops in the New Global Economy," *The Object of Labor, Art, Cloth and Cultural Production* (Joan Livingstone & John Ploof, eds). Chicago: School of the Art Institute of Chicago Press and Cambridge, MA: MIT Press, pp. 31–50.

page 33. According to Howard, quoting John R. Commons in 1901 and speaking of immigration to America, "The term 'sweating' or 'sweating system' originally denoted a system of subcontract, wherein the work is let out to contractors to be done in small shops or homes... The man best fitted to be a contractor... is well acquainted with his neighbors... who can easily persuade his neighbors or their wives and children to work for him, and who in this way can obtain the cheapest help."

"Workers toiling in dark, humid, stuffy basements on Division Street, children of eight years and women, many of them far from well, sweating their lives away in these hellholes' so shocked State License Superintendent Daniel O'Leary on an inspection of a garment shop in New York City in 1900, according to a contemporaneous account, 'that he asked the union for help and advice.' From *The Daily Forward*, November 21, 1900."

page 35. "Over the next quarter century, the struggle against the sweatshop ebbed and flowed with the political and economic tides of the nation... it became clear that the most effective weapon against the sweatshop and the most reliable indicator of progress in the battle was the organized strength of the workers themselves."

"Labor Secretary Frances Perkins reflected the tenor of the times in 1933 when she appealed to consumers to think about the human cost of a \$4.95 dress."

page 36. "By the mid 1960's... sweatshop(s) had been relegated to a minor nuisance, its very marginality the symbol of the American success story."

page 37. Under section heading: The Industry Goes Global: With the outsourcing of American manufacturing the problems of sweatshop labor have increased all over the world.

page 43. "When nationally based corporations ruled their own countries, trade barriers protecting national industries were official policy. In this area of transnational corporations, about 2,000 of which control half of the world's trade and three-quarters of its financial assets and have no national loyalties, it is their insatiable interest in consolidating access to the entire global market that animates the fashionable economic theories of the early twenty-first century."

page 45. "The first and indispensable order of business is to make the system visible and keep it in the public eye... But most of the elements of a successful strategy can be found in... public exposure and pressure, 'government action, corporate responsibility, and most critical of all - the empowerment of workers. A system of industry wide standards must be rebuilt."

page 46. "If companies really want to know what is happening in their contractors' shops offshore, they need credible independent monitors who have the confidence of the workers. This is a great virtue in the path-breaking programs established by the Gap in El Salvador or the Rugmark labeling campaign..."

"Legislation is needed that establishes 'joint liability' for retailers and manufacturers."

page 47. "The rules of the WTO restrict the ability of any single nation to deny entry of goods produced under conditions of which the importing country may find objectionable."

"[A] bill was introduced in the US Senate in 2006 that would prohibit the import, export, or sale of sweatshop goods in the United States."

page 49. "Workers and their unions in the apparel industry are now undergoing an historic adjustment of their strategic vision."

"The industry must be rationalized and humanized, and there is no greater force with the interest and capacity to do this than the workers themselves."

page 50. "Those (employers) who resist the establishment of decent standards in the industry must pay a price: fines from stepped-up enforcement, disrupted production from demoralized and angry worker, and the rejection of their goods by consumers increasingly sensitive to the conditions under which goods are produced."

"The force required to move institutions as powerful and entrenched as the modern transnational corporation is beyond the capacity of one group of workers or a single strata of the population. Sparks may fly from a strike in a factory...to invoke the spirit of the kind of movement we need today ... (to) invoke the action of masses, reverberate through the structure of the entire society, coalesce with allies, and eventually take political form..."

Triangle Shirtwaist Company Fire

Today American labor unions play an important role in manufacturing. They make it possible for workers to have a say in their work environments and in establishing laws that protect their safety and health. The pivotal event in labor union history, the 1911 Triangle Shirtwaist Company fire, changed the way labor unions were viewed by politicians and the public.

Here is a link to a brief description of the events of that day and the outcome:

<http://www.csun.edu/%7Eghy7463/mw2.html>

READING SUMMARY

From: Collins, Jane L. *Threads: Gender, Labor, and Power in the Global Apparel Industry*. Chicago: The University of Chicago Press, 2003.

Jane Collins's book *Threads, Gender, Labor and Power in the Global Apparel Industry* looks at the multifaceted apparel industry and sets about unraveling it in a number of ways. Collins takes us from the hand-made cloth of Europe and America to the mechanization of cloth production and the invention of the sewing machine to save labor, thereby increasing product and profits in the 19th century. The book goes on to look at the history of apparel production through two channels. The first involves the social structures of the industry and the second traces the industry's impact on global production processes and hence world economics. Collins tackles this complex topic through her own experience growing up in the mill-town-rich southern U.S. and twenty years of research on Latin America's textile industry.

Collins employs two fundamental business ideas to set up her argument: "Managers...have historically relied on gendered ideologies of sewing work to devalue women's skill and lower their wages"(16) and the idea that workers are controlled best by giving them the least amount of information possible to perform their jobs well. Because manufacturing work has stayed fixed in these modes women have even been denied the basic human right to information. In controlling the labor force this way, firms have been able to increase profits for Wall Street and deny workers the ability to organize.

What I find most interesting in this book is the historical account of women's participation in worker's rights organizations. Collins tells the classic struggle between firms and workers, asking, what is the price women must pay for the chance at a better life? The question of whether or not the price is worth it isn't even relevant in most cases, even today, because many of the women involved don't actually have a choice of labor. Sewing is the only job available to them.

According to Collins in the first years of the 20th century women began to organize. A group of seamstresses thought paying workers piecework for their labor lowered the quality of the clothing being produced. Wanting to maintain high standards in their work the women formed the Custom Clothing Worker's Union (CCWU)(the first headed by women) and lobbied for and won a (shorter) nine-hour workday, higher wages and a ban on child labor in the shops. In the compromise resistance to piecework failed and after affiliating with the American Federation of Labor (AFL) that organization ordered the CCWU to join the United Garment Workers where gendered struggles for a voice in quality production continued. This affiliation marks the decline of women's voices being heard on the factory floor, until the "uprising of 20,000" in 1909.(33). The most significant outcome of the uprising and subsequent agreement was that managers did not agree to unlock doors during work hours or to make fire escapes functional. Unfortunately, this led to the disastrous death of 146 young women in the Triangle Shirtwaist fire in New York City the next year. The only good thing to come from this event is our modern-day building code laws that have saved thousands of lives.

The book goes on to give several other accounts of the devaluation and control of women in the workforce, moving the discussion into the global sphere by discussing the women's organizations that have been established as a result of the maquiladoras, or factories in Mexico that import goods and parts, assemble them into new goods which are then exported--usually back to the original importer. The

first type of service organization was formed in the northern border region of Mexico to support women workers by providing information about their health, childcare, reproductive rights, safety and work concerns. Formed in the 1960s it is known as the Center for the Orientation of Women Workers (COMO). It provides educational opportunities and health campaigns allowing the workers to have a comprehensive, collective voice for the first time. These types of organizations bring together the public and private sectors to address the ways in which women negotiate these two worlds. The other type of organization important to women's collective voice -- and perhaps the most effective -- is the transnational organization. The Coalition for Justice in the Maquiladoras is a group of religious, environmental, labor and women's organizations in the U.S., Mexico and Canada. The sheer size and economic weight of this type of organization can make firms adhere to socially responsible practices.

READING SUMMARY

From: Sherlock, Maureen P. "Piecework: Home, Factory, Studio, Exhibit." *The Object of Labor, Art, Cloth and Cultural Production* (Joan Livingstone & John Ploof, eds). Chicago: School of the Art Institute of Chicago Press and Cambridge, MA & London: MIT Press, pp. 1-30.

p. 1. "Lighting up the firmament of the Church of Designer Names, the spectacle of these icons averts the mind's eye from child labor in Indonesia and sweatshops hidden in every immigrant neighborhood in the United States."

p. 2. "The fates of art and fashion are tied to the forms of the dominant social system, sometimes leading, sometimes lagging, but always intertwined with its ideological apparatus."

"In flexible accumulation someone always pays..."

"[E]very aspect of the economy has moved from values like durability or function to that of the 'new'."...One's shelf life in art may seem to be a little longer...but even here the spell of the commodity transforms artists' works not into masterpieces but dated and mannered moments in the spectacle of art making."

p. 4. "Each artist must choose his or her own place in the struggle...More importantly, is art even capable of being anything more than a commodity in a game of high-end money laundering or aesthetic colonialism?"

p. 5. "[E]ven our self-definitions come through the prism of products made to shape us in their image."

"Like other displaced workers, artists increasingly rely on piecework for their survival: odd jobs without health insurance, fabricating for other artists, remodeling, and food services. Piecework is often marginalized in discussions of the industrial growth of factories, but it is the other side of capital and is often called by another name -- sweating..."

p. 7. "According to Julian Stallabrass, the failure of both a political and creative avant-garde on an international level left us with no coherent alternative narrative of a world beyond capitalism."

p. 13. "If it is true that the life which exists in the worker's body is transferred through the production process to the commodity, thereby creating the illusion that capital has a body of its own and is capable of reproduction, then it is also true that

the marketing of objects as diverse as designer art schools or high-heeled shoes takes its light from the transformation of the blood of others."

p. 16. "Frederick W. Taylor...turned over both segmentation and the *speed* of production from the workers to management... He took virtually all control, including safety and health, out of the producer's hand, thus rendering him/her mindless."

"Since they only produce one section of abstract labor, they lose a sense of being a producer, the subject of their own acts, or masters in some small part of their fate."

p. 17. "Though artists understand their own subjectivity and creativity as separate from industrial production, they fail to take note of the similarities....Having little or no control over the institutional legitimation necessary to promote the distinction of their work, they also lose control of their art once it is paid for and transformed into a mere commodity."

p. 18. "The 'political' art that began surfacing in the seventies and eighties was canalized back into the realm of the personal and its identity politics....There is a great difference between addressing an audience with conflictual issues and merely confronting them with bad-boy art."

p. 20. "Museums too have undergone a series of changes consonant with the dominant social system... Early Renaissance collections of treasured objects or plunder were modeled on...cabinets of curiosity....Later...'scientific' lighting enabling close inspection brought the separation of one work from another by 'empty space.'"

p. 21. "History comes to the museum with the French Revolution's transformation of the Louvre palace into a public display of the Republic's wealth 'repossessed' from the defeated royal crown."

"The Metropolitan Museum of Art during the Reagan Presidency revealed its class bias with shows 'appointed' by fashionista Diana Vreeland, a consulting curator for its fashion department. Vreeland openly colluded with Bloomingdale's department store in New York to present a series of French couture and historical costume exhibitions. Vreeland was a bellwether of what was to come for many museums: first, she could raise much needed revenues for blockbuster shows from the private sector who could benefit from tie-in publicity, and, second, she retooled the museum's stores both within the museum and in its secondary satellites. Surface style became more important than history and substance, for what is good for Yves St. Laurent is good for the Metropolitan and *Harper's Bazaar*!"

p. 22. "The Queen of Fashion dictated a New Conservatism in women's clothes, thus announcing the demise of the Women's Movement and the return of the fashionable woman with one wave of her hand."

"The latest stage of the museum's 'capital development,'... is the transformation of the museum into a literal corporation. [Guggenheim Museum]"

"In the nineteenth century, especially in France, the interior of the middle class home developed parallel to both the department store and the museum. The bourgeois domestic begins to be seen as a private museum that will soon need its own curators or 'taste professionals' to arbitrate between the home's competing objects, both old and new."

p. 24. "In our own time, Martha Stewart restores the home as the site of imaginary production."

p. 25. "Martha Stewart is important because she recognized that women had a real sense of loss over that fictive woman who did it all from scratch."

"We must not lose sight of the fact that these modes of private life and desire are clearly not extended to most of the working classes of every developed country in nineteenth- and early-twentieth-century life."

p. 26. "As the department stores with their polished glass cases disguised the origin of the fancy work on sale, so too the homework of the sweated poor was invisible until conditions became so bad that middle-class women organized counter displays of their conditions."

p. 27. "And what is our role as artists and intellectuals in the twenty-first century when we realize that so many of us have been turned into specialists, apologists, and mouthpieces for the dominant order?"

p. 28. "Pierre Bourdieu calls on us to carry the Enlightenment's torch of knowledge back into the cave of the shadow puppets of religious and state terrorism: 'I would like writers, artists, philosophers and scientists to be able to make their voice heard directly in all the areas of public life...I think that everyone would have a lot to gain if the logic of intellectual life, that of argument and refutation, were extended to public life.'"

READING SUMMARY

From: Bowe, John. *Nobodies, Modern American Slave Labor and the Dark Side of the Global Economy*. New York: Random House, 2007.

The book *Nobodies* explores modern American slavery, power structures, corruption and their impact on our values as a society. Bowe calls our attention to the connection between the global market and those whom it exploits. To make this point clear, he quotes the Latin proverb *homo homini lupus* -- Man is a wolf to man. He calls to task Americans' insatiable hunger, which is actually revealed in the more-for-less attitude that we cloak in the belief that cheap goods, high employment and peace do not come at someone else's "high" price.

Bowe writes in brilliant prose backed up by several years of field investigation and research. He presents the book in three sections or cases. The first, "Florida," is a straightforward case of slavery prosecuted in the courts, involving farm workers forced to work without pay and without the ability to leave. This case raises questions about who we are and how we behave as consumers. I certainly never asked myself how free the person was who made my orange juice before reading this book. The second case is less clear-cut. It tells of a welding company located in Tulsa, Oklahoma, that was started by the son of a sharecropper, his rise to success in the US oil industry and eventual move to recruit workers internationally to expand into global markets in 1998. Ultimately Bowe asks us to decide whether or not true slavery was involved in this equation or whether manipulation and greed were present on both sides. Whichever side of this case we end up on, it's clear Bowe's quote "man is a wolf to man" applies.

The third case, "Saipan," takes a broad look at current attitudes about the practice of slavery in a place with the highest per-capita slave rate in the US. (Saipan is a US commonwealth.) At the beginning of the book Bowe quotes a 2003 article from The New York Times, "I Came, I Bought and I Helped," which states: "The onetime darling of Seventh Avenue, Isaac Mizrahi, was hired last year by Target to bring style to shoppers in forty-seven states. Critics were nearly unanimous in their

celebration... Few stopped to inquire how it was possible to attain Mizrahi chic for as little as \$9.99. Mr. Mizrahi's clothes are manufactured at factories around the world, said Lena Klostad, a Target spokeswoman, who declined to name specific countries... 'We have standards for all our vendors and a compliance area that takes care to enforce them,' she explained, 'so Isaac is freed up to focus on what he enjoys, the design.' When asked if he knew where his bargain styles were being manufactured, under what circumstances and by whom, Mr. Mizrahi pleaded ignorance. "I don't know," he said. "And I don't want to know." I was stunned when I first read the quote, but should I have been?

This book is a wake-up call to consider the implications of championing globalization without questioning its impact on the human condition. Bowe asks us to question the choices we make with our purchasing power and their impact on others, as well as current ideas about the value of local markets, the handmade, slow movements, and where we are headed as a society.

READING SUMMARY

IKEA: *The Ikea Position on Child Labour*, published 10-12-2007
<http://193.108.42.168/repository/documents/1507.pdf>

While searching for information on child labor I stumbled across Ikea's policy. Ikea is a Swedish-based multi-billion dollar corporation that contracts with suppliers all over the world to manufacture inexpensive, well-made home-furnishing products for the masses. The document discusses the company's policies and practices, the international conventions it adheres to, and the NGOs (non-governmental organizations) and other international organizations it works with to prevent child-labor abuses in the places where it conducts business. The document discusses the carpet production industry as an example, and I was surprised to read this statement: "The production of carpets in India is spread over a large geographic area and divided into small units, sometimes right down to individual household looms in villages scattered across the countryside. This widespread production makes it very challenging for Ikea...to guarantee 100% that no child at any time is involved in the production of a product. Consequently, Ikea is hesitant to put any labels on its products that can give an illusion of guarantees." In publicly acknowledging its inability to guarantee that no child labor is used in the manufacture of their goods and also discussing what it is doing to try to combat the problems of child labor, Ikea is taking steps to bring awareness to the issue. While reading this document and taking into account that Ikea is a business whose main goal is to make a profit for its shareholders, I am cautiously encouraged to think that perhaps the motivations of some corporations are evolving from the bottom-line-only mentality of the past.

READING SUMMARY

Isaacson, Andy. "The Second Coming of Nau, One of the most sustainable outdoor brands on the planet gets a second chance, Will it last?" *National Geographic Adventure*. Volume 10, Number 10, December 2008, pp.

After reading this article that covers the start-ups beginning in 2005, and recent near demise and rebirth, I was curious to know more so I went to their website. Here is what I found:

Where We Stand

Furthermore, for many of the products Nau is producing (some of the most highly tailored and technical on the market) the required skill sets and technologies no longer exist in the U.S. While there are U.S.-made garments available to consumers, they are almost always less technical than what Nau designs, and are produced in far greater volume. The demise of the U.S. textile and garment-manufacturing segment of the economy is a well-known macro-economic trend, in place for many years.

While disappointing, this is not something that we, as a small newcomer brand, can truly counteract.

What We're Doing

Besides working with manufacturers with whom we have long-established relationships, we have created a code of conduct with which they must comply. Our Code of Conduct addresses three major areas: human rights, environment, documentation and review. The human rights section addresses issues related to voluntary employment, child labor, freedom of association, fair and equal treatment, nondiscrimination, compensation, hours of work, overtime, and health and safety. To ensure such principles are being upheld, we contract a third-party, non-profit audit firm, Verite, to perform systematic inspections of facilities and reviews of production.

Selected Socially Responsible Companies / Organizations

Fair Labor Association, <http://www.fairlabor.org> This organization is dedicated to ending sweatshop labor worldwide with sustainable solutions.

Verité Services and Programs, <http://www.verite.org/services/services.html>, Verité is the pioneer in developing workplace solutions through state-of-the-art social and environmental auditing, practical training, program building, and innovative education and research programs for factories, workers, NGOs, corporations, investors, and governments. In helping companies and supply chain stakeholders find innovative solutions to workplace problems, we improve social and economic opportunities for workers world wide. With the welfare of workers at the center of our efforts, we have developed a global reputation for assessing and guiding change for continuous improvements in workplaces around the globe.

Rugmark Foundation, <http://www.rugmark.org/home.php>, RugMark was formally established in 1994 by a coalition of nongovernmental organizations, businesses, government entities, and multilateral groups like UNICEF. The first carpets bearing the RugMark label were exported from India at the beginning of 1995, mainly to Germany. RugMark is working to end illegal child labor in the carpet industry and to offer educational opportunities to children in South Asia.

National Green Pages, <http://www.coopamerica.org/pubs/greenpages/index.cfm> Includes listings of retailers that do business with fair trade companies.

WORLD TEXTILE MANUFACTURING

Textile manufacturing tends to move according to where workers are plentiful, wages are cheap, and favorable business incentives are offered. Initially textile manufacturing moved from Europe to the United States in the early 1800's. The first textile mills were set up in New England where immigrant workers congregated, and water-powered mills were being built. Around the mid-1850's when New England workers began to organize for better working conditions and higher wages, textile mills moved to the southeastern United States. Again in the 1950's when southern workers began to unionize and wages rose, textile factories moved to Mexico, and then to other South American countries. Finally, in the late 1900's, manufacturing moved off shore to wherever the cheapest labor and most favorable business conditions could be found. One current center of textile production disputes about workers' wages and working conditions is located in Egypt.

"Man-Made Tsunami" by Huck Gurman, *Common Dreams New Center*, Jan 13, 2005
<file:///localhost/Users/awilso/Documents/Eudora Folder/Attachments Folder/Man-Made Tsunami.webarchive>

This essay discusses the 1973 Multi-Fiber Agreement that set international textile quotas allowing developing nations access to international markets and hence the creation of large numbers of new jobs. The expiration of that agreement on January 1, 2005 has had devastating consequences. According to Gutman: "Yet, the suffering brought about by this tidal wave of unemployment [created by ending the quotas] and the national economic catastrophes which ensue will quite literally dwarf the immense suffering which has been the consequence of the historic tsunami in the Indian Ocean." The essay gives an in-depth account of the causes and outcomes of this 'man-made tsunami' that we are now perhaps witnessing in the world economic crisis of our financial systems.

"Lesotho textile workers left in rags," Basildon Peta, April 28, 2005
<http://www.thestar.co.za/index.php?fSectionId=225&fArticleId=2500450>

This article gives a succinct account of the "Chinese Tsunami" effect Chinese textile manufacturers are having on African countries and the world-wide repercussions.

"Egyptian textile workers win victory," Mark Osborn, September 30, 2007
Source: No Sweat <http://www.nosweat.org.uk/node/605/print>

"Egyptian Workers Impose a New Agenda," Asma Aghbarieh Zahalka, May 29, 2008
Source: Union Ideas Network: <http://uin.org.uk/content/view/272/123/>
This article gives a detailed account of the strikes in Mahalla al-Kubra, Egypt, in 2007.

ESTIMATED TEXTILE WORKER PAY SCALES IN VARIOUS COUNTRIES

United States

Source: State University.com

<http://careers.stateuniversity.com/pages/562/Apparel-Workers.html>

Earnings in the apparel industry vary by occupation.

These median hourly figures were reported in May 2004:

Patternmakers \$13.85

Cutters \$9.80

Sewing \$8.61

Some apparel workers belong to labor unions, like UNITE HERE! Benefits vary, but may include paid holidays and vacations, health insurance, pension plans, and childcare.

Source: Payscale online

http://www.payscale.com/research/US/Job=Weaver/Hourly_Rate

Source: US Department of Labor Statistics

<http://www.bls.gov/oco/ocos233.htm#earnings>

Earnings of textile, apparel, and furnishings workers vary by occupation. Because many production workers in apparel manufacturing are paid according to the number of acceptable pieces they produce, their total earnings depend on skill, speed, and accuracy. Workers covered by union contracts tend to have higher earnings. Median hourly earnings by occupation in May 2006 were as follows:

Fabric and apparel patternmakers	\$15.74
Extruding and forming machine setters, operators, and tenders, synthetic and glass fibers	13.78
Upholsterers	13.09
Textile knitting and weaving machine setters, operators, and tenders	11.68
Textile bleaching and dyeing machine operators and tenders	11.20
Textile winding, twisting, and drawing out machine setters, operators, and tenders	11.08
All other textile, apparel, and furnishings workers	11.03
Tailors, dressmakers, and custom sewers	11.01
Shoe machine operators and tenders	10.54
Textile cutting machine setters, operators, and tenders	10.39
Shoe and leather workers and repairers	9.83
Sewers, hand	9.79
Sewing machine operators	9.04
Laundry and dry-cleaning workers	8.58
Pressers, textile, garment, and related materials	8.56

Benefits vary by size of company and work that is done. Large employers typically offer all usual benefits. Apparel workers in retail trade also may receive a discount on their purchases from the company for which they work. In addition, some of the larger manufacturers operate company stores from which employees can purchase apparel products at significant discounts. Some small firms and dry-cleaning establishments, however, offer only limited benefits. Self-employed workers generally have to purchase their own insurance.

Source: Union Ideas Network: <http://uin.org.uk/content/view/272/123/>

From an article written by Asma Aghbarieh Zahalka, Thursday, 29 May, 2008

This article contains content about the pay of textile workers in Egypt.

A worker on the high end of the pay scale at Misr Weaving makes \$180 per month after overtime pay and fringe benefits are figured in. The UN defines poverty in Egypt at \$2 per person per day. Since an Egyptian worker supports, on average, 3.7 persons, he would have to make \$224 to surmount the poverty line. The public sector includes 28% of the country's workforce (6 million out of 22 million), and the incomes here (as in much of the private sector too) are far below \$224.

Source: My Future Australia

<http://www.myfuture.edu.au/services/default.asp?FunctionID=5420&ASCO=311279A#TextEarningsTable>

Textile Technician wages in Australian dollars

Source: Canadian News

Bangladesh textile workers to get wage rise

<http://www.canada.com/calgaryherald/news/story.html?id=a64a6ea7-0591-4737-b446-93bef75bac30>

Published: Saturday, August 09, 2008

DHAKA (Reuters) - Workers in Bangladesh's export-oriented knitwear manufacturing factories will get a pay rise of about 20 percent from next month due to increases in the cost of essentials, a business leader said on Saturday. "The decision was approved today in the board meeting of our association to reduce the sufferings of the workers and also to raise the productivity of them," said Mohammad Fazlul Haque, president of Bangladesh Knitwear Manufacturers and Exporters Association (BKMEA). Knitwear is the largest export earner of Bangladesh, employing 800,000 workers in more than 1,500 factories, he said.

Sweatshop Wages

According to the website: "Who Makes It"

<http://spot.colorado.edu/~shortk/makes.html>

The following hourly wages paid to garment workers in sweatshops in 1995:

Hong Kong - \$3.63, Malaysia - \$0.49, Phillipines - \$0.48, Thailand - 0.38-0.48, Sri Lanka - \$0.13, China - \$0.12-\$0.15, Vietnam - \$0.12

This story documents findings of sweatshop conditions in the U. S. in 2008

<http://www.cnn.com/2008/US/07/23/garment.workers/>

"N. Y. Officials: Factory for Big Retailers 'paid sweatshop wages'" 7/23/2008

"Women and Sweatshops"

<http://www.webster.edu/~woolfm/sweatshops.html>

According to this article, wages in sweatshops are often reported to be between \$0.10-\$0.20 per hour. The article also chronicles sweatshop conditions, U. S. companies with ties to sweatshops activities, and efforts to end sweatshops.

Garment workers hourly wages as reported by fairwear.org.au

<http://www.fairwear.org.au/engine.php?SID=1000004&AID=100087>

in an article titled: "International Sweatshop Campaign/Ezyworker Action"

China - \$0.46, India - \$0.52, Vietnam - \$0.29, Indonesia - \$0.21, Sri Lanka - \$0.58

Also of interest on the same site is a spoof about sweatshop issues:

WATCH the 9-minute interview with Ezyworker activists and FairWear representatives talking about the undercover action on YouTube at:

<http://www.youtube.com/watch?v=iuV2YVhvN8U>

While researching sweatshop wages, I was unable to find verifiable sweatshop wage figures for workers in the United States. -KP

ART / CRAFT / COLLECTIVE PRACTICES

READING SUMMARY and ANNE WILSON / KEVIN MURRAY CONVERSATION

Zimmerman, Jean. *Made from Scratch, Reclaiming the Pleasure of the Hearth*. New York: Simon & Schuster, 2003.

Kevin Murraray links:

<http://www.craftculture.org/review/kmurray1.htm>

<http://www.craftunbound.net/>

Jane Zimmerman's book *Made From Scratch, Reclaiming the Pleasures of the American Hearth* discusses the practice and appreciation of craft-based traditions as they have been passed down from generation to generation. While the book has a nostalgic tone, the ideas in the book speak to broader issues of where we are headed as a society and the cultural consequences of losing hand-making skills.

As Kevin Murray reflected in a conversation with Anne Wilson at the time of his 2007 SAIC lecture: "China is a huge world leader in production; we in Australia (Europe and US) are the thinkers and designers. As China advances, it will also become a center of conceptualizing and design. As we continue to close out factories and outsource our production elsewhere and thereby lose our knowledge of skill-based production -- where will that leave us as viable players in the future?"

With the abundance of corporate branding and market training to promote consumption, issues of personal agency are becoming more critical than ever. In the past 10 years, there has been a resurgence of DIY practices internationally, and many artists are working from the platform of individual agency and the hand-made. (Cat Mazza, *Microrevolt* - <http://microrevolt.org/mission.htm>; Shannon Stratton and Judith Leemann, *Gestures of Resistance* - <http://www.performingcraft.com/home>; Carole Lung, *Sewing Rebellion* - <http://www.fraufiber.com/>; and many others).

As the global market forces us to specialize, new technologies allow us to transcend geography and communicate faster than ever before. Our high-tech, fast-paced world has its benefits, but staying grounded and taking time to tend and nurture locates us in the present. As Zimmerman points out, the ancient rituals of making food, shelter, and crafting engage us as individuals in a community.

BIBLIOGRAPHY

Please refer to separate link for "bibliography" on exhibition web site.